



**Electrolux**  
PROFESSIONAL

**Modular Cooking Range Line  
thermaline 80 - 600mm Passth. Electric  
Warming Cabinet, 2 doors, GN conform,  
2 Sides(H2)-H=550**

ITEM # \_\_\_\_\_

MODEL # \_\_\_\_\_

NAME # \_\_\_\_\_

SIS # \_\_\_\_\_

AIA # \_\_\_\_\_



**588318 (MA4JDCFOAO)**

Passthrough electric warming cabinet, with 2 doors, two-side operated, GN - H2

### Short Form Specification

**Item No.** \_\_\_\_\_

600 mm wide passthrough warming cabinet with 2 doors, constructed according to DIN 18860\_2 with 70 mm recessed plinth. Internal frame for heavy duty sturdiness in 2 mm and 3 mm in 1.4301 (AISI 304). 2 mm top in 1.4301 (AISI 304). Flat surface construction

### Main Features

- All major components may be easily accessed from the front.
- THERMODUL connection system creates a seamless work top when units are connected to each other thus avoiding soil penetrating vital components and facilitating the removal of units in case of replacement or service.
- Unit constructed according to DIN 18860\_2 with 70 mm recessed plinth.
- Temperature in the cupboard can be set through a thermostat to suit different requirements. The maximum temperature is 110°C.
- Unit can be installed below modular top appliances, designed to keep plates warm.

### Construction

- IPX5 water resistance certification.
- 2 mm top in 1.4301 (AISI 304).
- Flat surface construction with minimal hidden areas to easily clean all surfaces
- Storage space in the base of the appliance accepts GN1/1 containers.
- Internal frame for heavy duty sturdiness in stainless steel.

**APPROVAL:** \_\_\_\_\_



Experience the Excellence  
[www.electroluxprofessional.com](http://www.electroluxprofessional.com)

Front

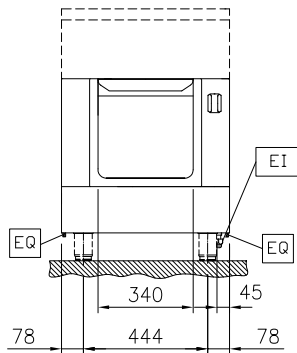

Side

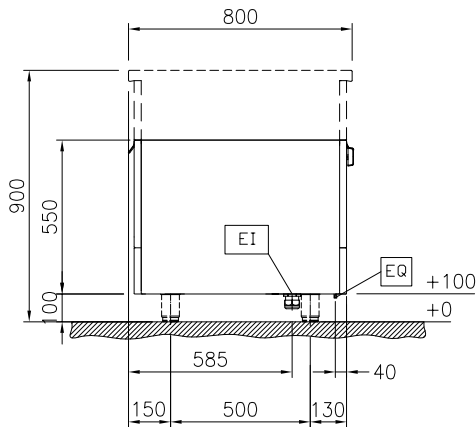

EI = Electrical inlet (power)

Top

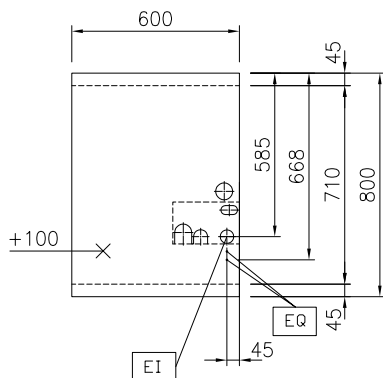
**Key Information:**

External dimensions, Width:	
588318 (MA4JDCFOAO)	600 mm
External dimensions, Depth:	800 mm
External dimensions, Height:	550 mm
Cupboard Cavity Dimensions (width):	340 mm
Cupboard Cavity Dimensions (height):	330 mm
Cupboard Cavity Dimensions (depth):	710 mm
Cabinet temperature range:	30-110 °C
Net weight:	28 kg

**Sustainability**

Current consumption:	2.5 Amps
----------------------	----------

## Optional Accessories

- Stainless steel side panel (12mm), 800x800mm, freestanding PNC 912508
- Stainless steel front kicking strip, 600mm width PNC 912596
- Stainless steel side kicking strips left and right, freestanding, 800mm width PNC 912619
- Stainless steel plinth, freestanding, 600mm width PNC 912823
- - NOT TRANSLATED - PNC 913233
- - NOT TRANSLATED - PNC 913244
- - NOT TRANSLATED - PNC 913257
- - NOT TRANSLATED - PNC 913279
- STAINLESS STEEL DIVIDING PANEL 800X800MM LEFT/RIGHT PNC 913669
- ELECTRIC MAINSWITCH 25A 4mm<sup>2</sup> NM FOR MODULAR H800 ELECTRIC UNITS (FACTORY FITTED) PNC 913676
- - NOT TRANSLATED - PNC 913685